

MODEL #14050

ASSEMBLY INSTRUCTIONS

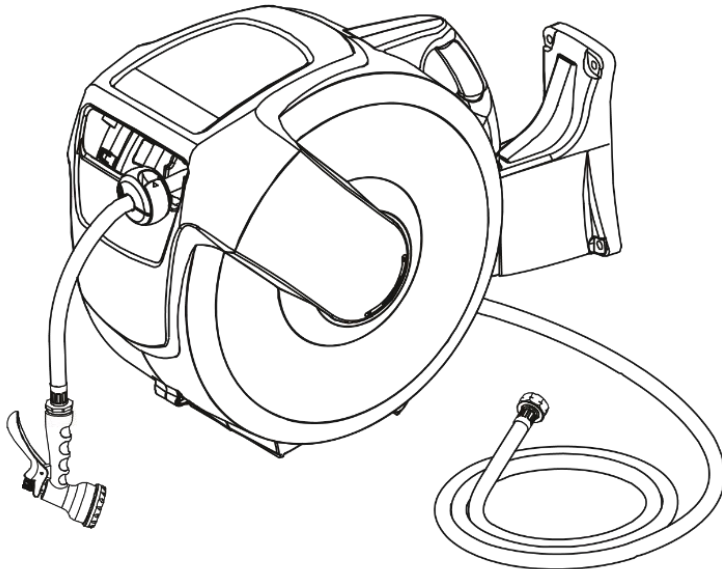

SPECIFICATIONS:

Hose diameter: 5/8 inches

Inlet hose length: 6 feet / 2 meters

Max. operating pressure: 75 psi

Thank you for selecting EarthWay for your lawn and garden needs.

Our customer support team is standing ready to ensure your success. Please visit our website to see our other lawn & garden tools.

IMPORTANT

- READ THE ENTIRE GUIDE BEFORE INSTALLATION OR USE.
- CONNECT ONLY TO WATER SOURCE WITH PRESSURE AT OR BELOW 75 PSI.
- RELEASE WATER PRESSURE WHEN NOT IN USE.
- PRODUCT CONTAINS CHARGED SPRING. DO NOT DISASSEMBLE HOUSING.
- DO NOT DRINK FROM HOSE.
- ALLOW WATER TO RUN FOR 30 SECONDS. BACTERIA WILL FORM IN STANDING WATER.
- IN FREEZING CLIMATES – BEST OPTION IS TO TAKE REEL INDOORS. OTHERWISE, DISCONNECT & COMPLETELY UNCOIL HOSE TO DRAIN REMAINING WATER.

PACKAGE CONTENTS

- A. Instruction Manual
- B. Hardware Pack
- C. Hose Reel
- D. Mount Bracket

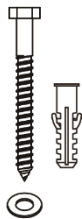

- B.1 Screw (×4)
- B.2 Washer (×4)
- B.3 Anchor (×4)

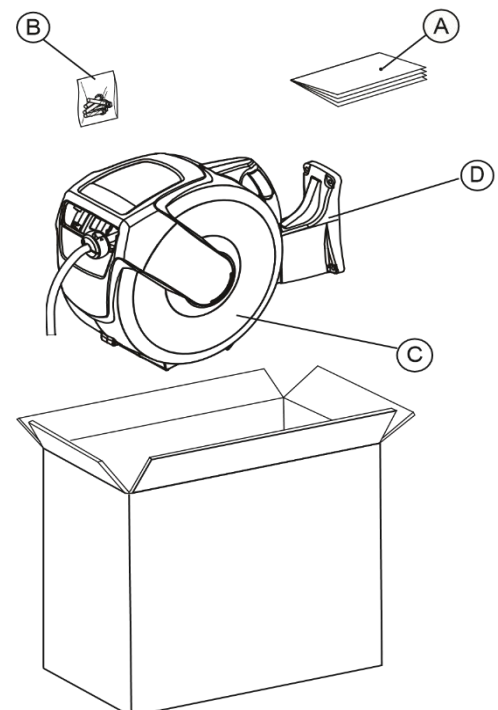

CHOOSING THE BEST MOUNTING LOCATION

This product can be mounted in many different ways. It is important to select your mounting location carefully. Consider mounting:

1. Near your water source. This product includes **15m (50ft)** of outlet hose. Make sure it can reach your garden.
2. Near your water supply. This product includes **2m (6ft)** of inlet hose. Make sure it can reach your water supply.
3. Out of direct sunlight.
4. Post or wall that will support 50 lb load. If unsure, contact a professional installer.
5. Refer to the installation options below for more detail.

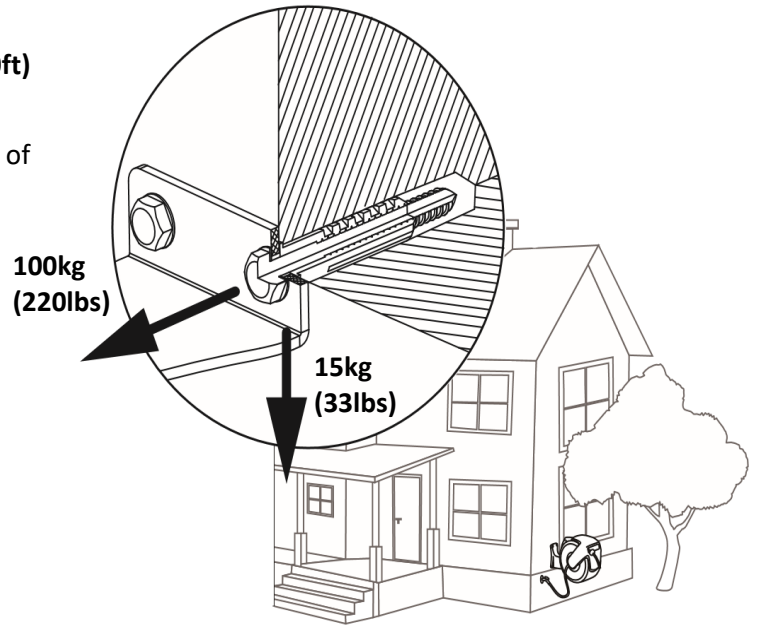

INSTALLATION



WARNING: IF NOT PROPERLY INSTALLED, THERE IS A RISK OF HOSE REEL FALLING. **MAKE SURE YOUR INSTALLATION CAN SUPPORT THE LOADS ABOVE.**



CAUTION: WHEN USING POWER TOOLS SUCH AS AN POWER DRILL, PLEASE **WEAR EYE PROTECTION.**



WARNING: ENSURE THERE ARE NO LIVE ELECTRICAL WIRES OR PLUMBING IN THE WALL AT THE LOCATION YOU ARE DRILLING.

DIRECT MOUNT TO WOOD STUD

Recommended tools:

- masking tape
- stud-finder
- bubble level
- power drill
- drill bit - 3mm (1/8 in)
- 10mm socket, wrench or adjustable wrench

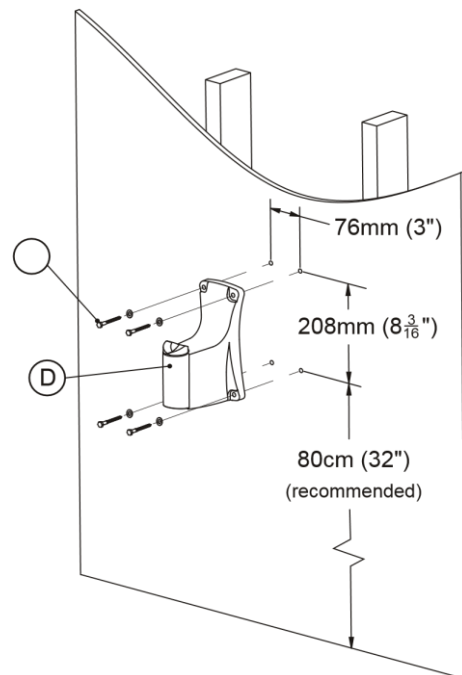

Mounting Steps

1. Using stud-finder, locate stud and mark the location.
2. Tape the drilling template on the wall at a convenient height, making sure the holes are centered on the stud.
3. Check the hole centers with the level to ensure they are plumb.
4. Drill (4) four holes with a Φ 3mm (Φ 1/8in) masonry drill bit on the template centers.
5. Fasten the mounting bracket with four lag bolts and washer to the wall or timber post.
6. Hang the hose reel on the wall bracket and secure it by inserting the mount tube.
7. Connect with inlet hose end with the water source.

MOUNT TO HOLLOW WALL AND MASONRY WALL

Recommended tools:

- masking tape
- bubble level
- power drill
- Φ 10mm (Φ 3/8 in) drill bit
- hammer or mallet
- 10mm socket, wrench or adjustable wrench

Steps

1. Tape the drilling template on the wall at a convenient height, making sure the holes are between studs.
2. Check the hole centers with the level to ensure they are plumb.
3. Drill (4) four holes with a 10mm (3/8in) masonry drill bit on the template centers.
4. Tap plastic anchors (B.3) into holes with a hammer or mallet.
5. Fasten the mounting bracket with four lag bolts and washer to the wall or timber post and ensure drive mounting screws into the plastic anchors) in wall.
6. Hang the hose reel on the wall bracket and secure it by inserting the mount tube.
7. Connect with inlet hose end with the water source.

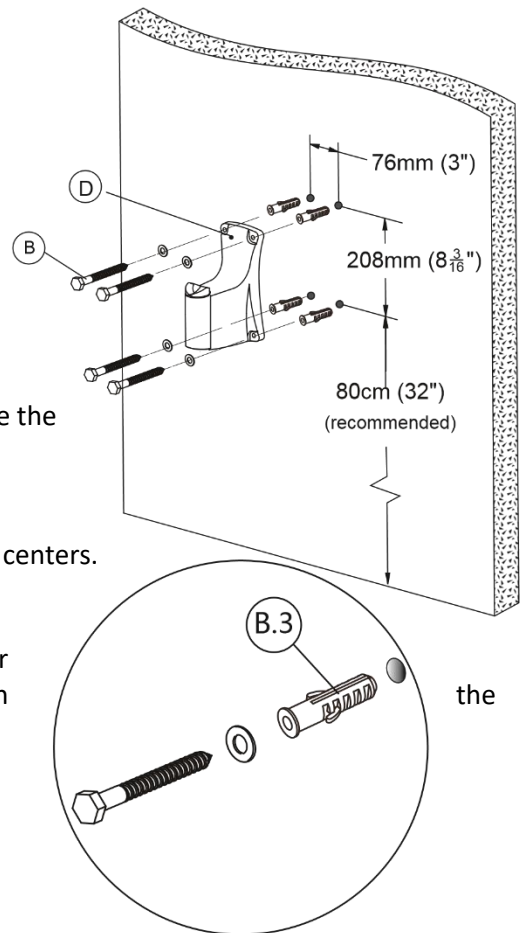

OPERATING INSTRUCTIONS

- **WARNING:** ALWAYS HOLD THE HOSE REEL UNTIL IT COMPLETELY RETRACTS INTO THE HOSE REEL.
- **WARNING:** THE YELLOW TAPE MARKS ON THE END OF HOSE LENGTH.
- **RELEASE WATER PRESSURE WHEN NOT IN USE.**
- **CAUTION:** DO NOT RELEASE THE HOSE ALLOWING TO REWIND ON ITS OWN.

1. Pull the hose out to the desired length. The hose will automatically lock in position.
2. To unlock and retract, give the hose a short pull. Walk the hose back to the hose reel. If you pull the hose longer than 12 inches you may re-lock the hose.
3. To avoid injury and damage, always hold the hose while it is retracting.
4. If the hose becomes tangled and will not retract - slowly pull out the hose past the tangled section and then allow the hose to slowly retract while guiding the hose back into the hose reel. Always ensure the hose is clean and not twisted.

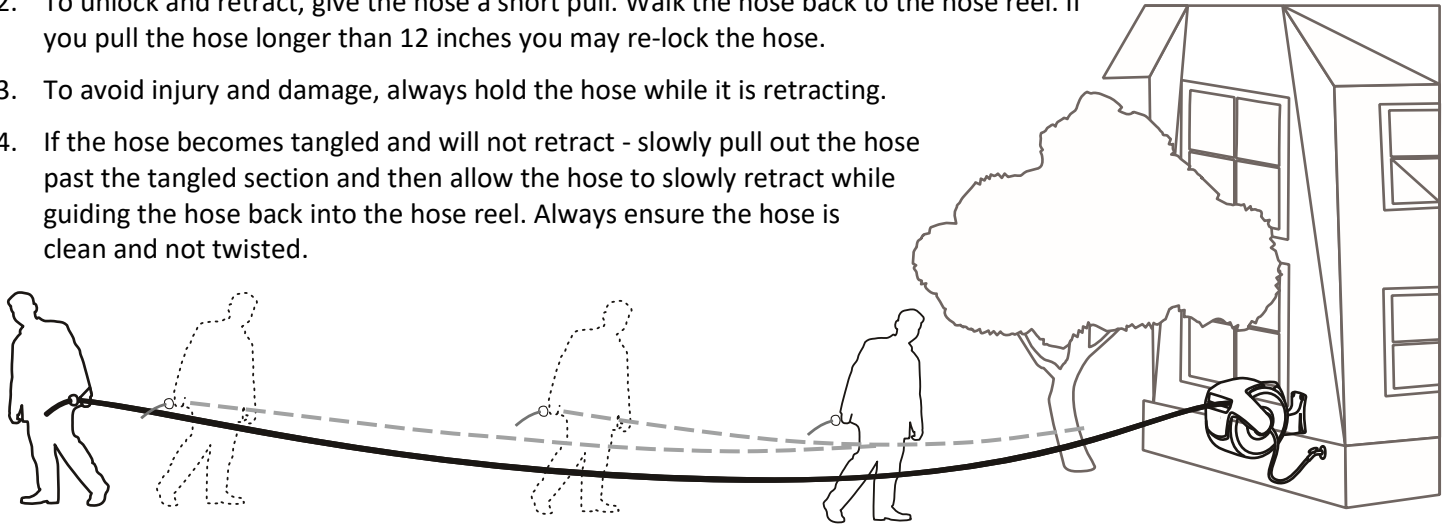

ADJUSTING THE STOP-BALL

The stop-ball location can be adjusted to ensure the hose is always within reach.

Recommended tools: No tool is needed.

Steps

1. Pull out the hoses to the desired length, ensuring the hose reel is locked (will not rewind).
2. Open the latch on the stop ball and move it to the desired location.
3. Re-latch the ball.



CAUTION: ALWAYS MAKE SURE THE HOSE REEL IS LOCKED BEFORE REMOVING THE STOP-BALL, AND MAKE SURE THE STOP BALL IS SECURELY FASTENED BEFORE UNLOCKING THE REEL.

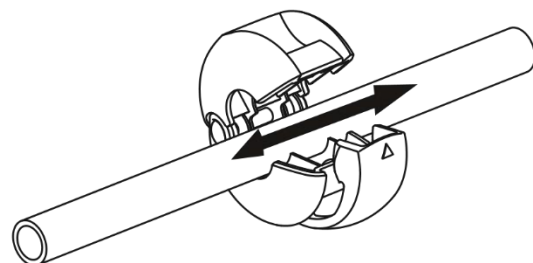
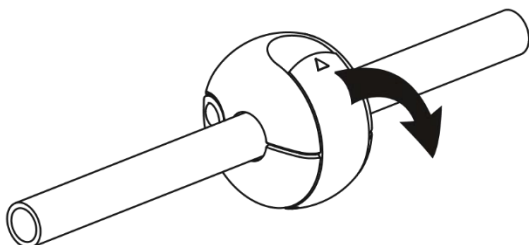

MAINTENANCE

While your product has been made with high quality materials, degradation can occur over time. Inspect the hose and housing periodically. If cracking or blisters are visible, discontinue use.



PRODUCT CONTAINS CHARGED SPRING. DO NOT DISASSEMBLE HOUSING

1. Always keep the hose clean.
2. If the hose becomes dirty, clean it with a damp cloth while retracting.
3. DO NOT twist the hose while in use.
4. Mount the hose reel in a sheltered area to assist and protect the performance of the hose and the reel.
5. DO NOT allow the hose to contact any corrosive chemicals or fluids.
6. Always retract the hose when not in use.
7. DO NOT drink from hose. Bacteria forms in stationary water (water standing in a hose).

CUSTOMER SUPPORT

SUPPORT@EARTHWAY.COM | 1009 Maple Street, Bristol, IN 46507

ONE YEAR WARRANTY

EarthWay Products, Inc. warrants this product free of defects in original workmanship and materials for a period of one year to the end user with the original purchase receipt. If a manufacturing non-conformance is found, EarthWay Products, Inc. at its discretion will repair or replace the part(s)/product at no charge provided the failure is not the result of incorrect installation, mishandling, misuse, tampering, or normal wear and tear as determined by EarthWay.

EarthWay at its discretion may require that the part(s) or product be returned along with the original purchase receipt for examination and compliance with the terms of this warranty. Do not return any product without first receiving authorization from EarthWay Products, Inc.

To seek remedy under this warranty, contact EarthWay Products, Inc. at support@earthway.com or write to EarthWay Products, Inc. 1009 Maple Street, Bristol, IN 46507 and describe the nature of the manufacturing defect. SPECIFIC LIMITATIONS: This warranty covers only the part(s) or product; any labor charges associated with repair or replacement of non-conformances are specifically excluded. Due to the corrosive nature of most fertilizers and ice melt products, EarthWay Products, Inc. makes no warranty against and specifically excludes part(s) or product degradation or failure due to corrosion or its effects.