

Visit our EarthWay website to see the assembly video

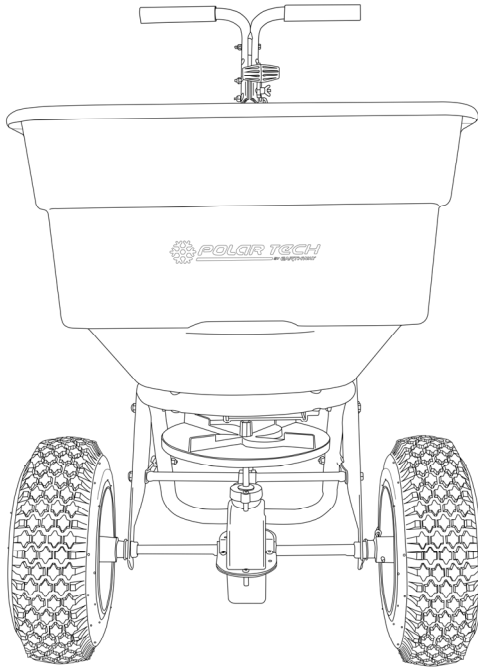

Prior to assembly, you will need:

Needle nose pliers

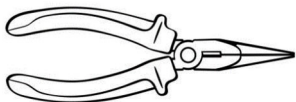

#2 Phillips screwdriver

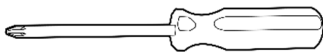

Two 7/16" adjustable or box wrenches

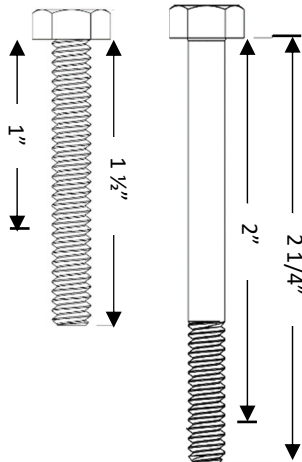

### THANK YOU



Thank you for selecting EarthWay for your spreader needs. Our production team in Northern Indiana takes pride in building this spreader. Our customer support team is standing ready to ensure your success.

Please contact us at [www.EarthWay.com](http://www.EarthWay.com) to see our full line of commercial, lawn & garden tools.

**NOTE:** The large opening is designed to allow ice melt to flow through spreader without the need for an agitator. This unit is not designed for fertilizer.

### ASSEMBLY HARDWARE

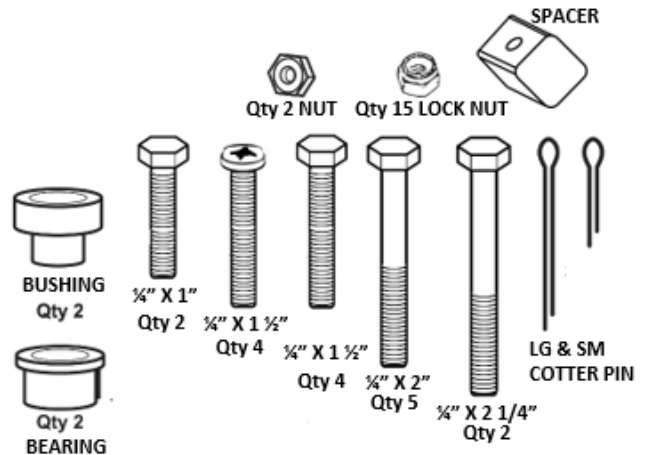

### SPREADER COMPONENTS

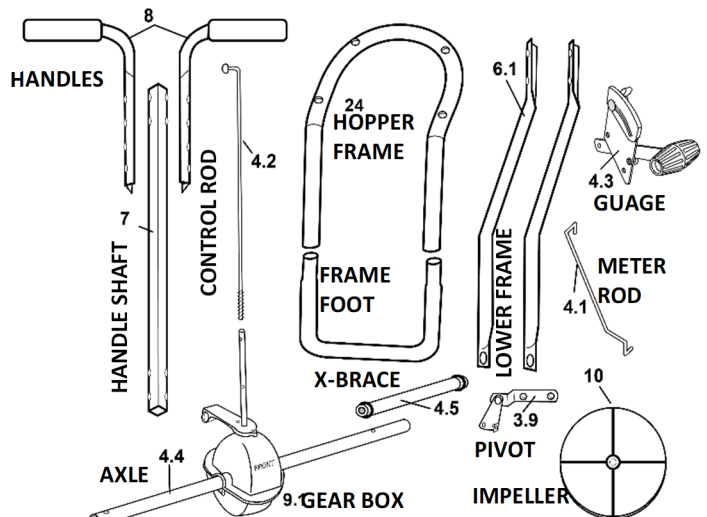

## HELPFUL HINTS

- ☑ Read the directions before assembly.
- ☑ If your spreader does not spread evenly, be sure “FRONT” on the GEARBOX points to the front of the spreader. **The impeller must turn clockwise when pushing forward.** Reversing the GEARBOX during assembly will cause issues.
- ☑ Your spreader is calibrated for three miles per hour, which is a brisk walking speed. Slower or faster speeds will change the spread pattern. **Do not use powdered materials as it will damage the gearbox.**
- ☑ Gears are permanently lubricated at the factory. Do not open the GEARBOX or dirt may enter.

## SPREADER ASSEMBLY INSTRUCTIONS

**Step 1:** Remove all components and hardware items from the box. Place the spreader hopper upside down and facing away from yourself.

**Step 2:** Install FRAME using (4) #14 x 1½” Flat Head Phillips screws. **TIGHTEN THESE NOW**

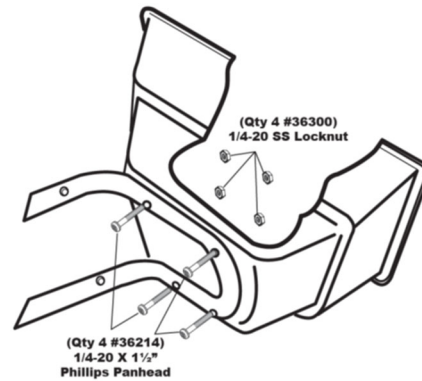

**Step 3:** Install impeller onto pinion shaft by pressing the impeller as shown onto the pinion shaft and turning the impeller while holding the pinion shaft to engage with the **COIN** fully, and press down to secure.

**Next,** insert Cross Brace thru the Gearbox Brace as shown above.

### GEARBOX ASSEMBLY

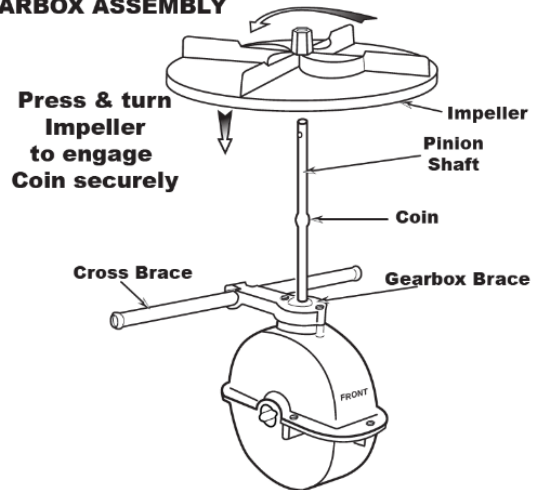

**Step 4:** Install GEARBOX by inserting the PINION SHAFT into hole in center of HOPPER bottom. The word "FRONT" on the GEARBOX must point to Front of the HOPPER.

**NOTE:** Place PolarTech brand towards the front of the hopper.

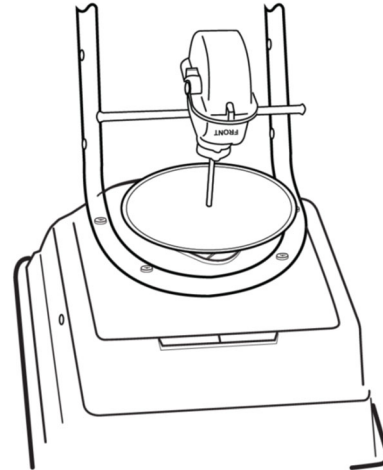

**Step 5: (A)** Install LOWER HANDLES onto FRAME to both sides as shown. Insert 2 1/4" bolt through hole in LOWER HANDLE and through hole in FRAME install locknut. **DO NOT TIGHTEN.**

**(B)** Now insert 1 1/2" bolt into the hole in LOWER HANDLE, then through FRAME brace. Next into threaded connector in CROSS BRACE. **DO NOT TIGHTEN**

**NOTE:** Numbers on frame brace must be facing toward gear box as shown.

**(C)** Install the FOOT into the FRAME and align the bolt holes in the FOOT and the FRAME (a Phillips screwdriver or large nail is helpful to align the parts)

**(D)** Next insert 1 1/2" bolt through other end of FRAME BRACE and through hole in FRAME through the FOOT and install locknut.

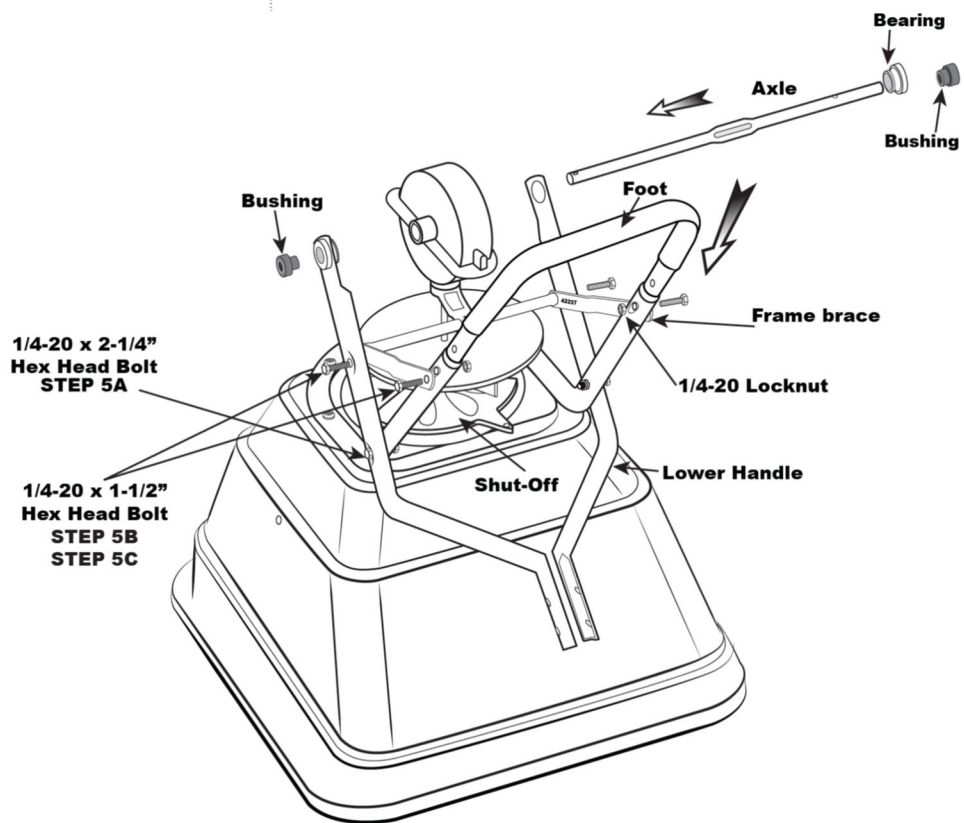

**Step 6:** Places the bearings into the lower frame using the “notch” on the bearing to fit into the “notch” on the LOWER AXLE FRAME. Next slide the axle through the bearings, through the GEAR BOX and into the other LOWER AXLE FRAME. Next, install AXLE BUSHING onto the axle, by placing the smaller end in first, slide over the AXLE, past the drilled holes.

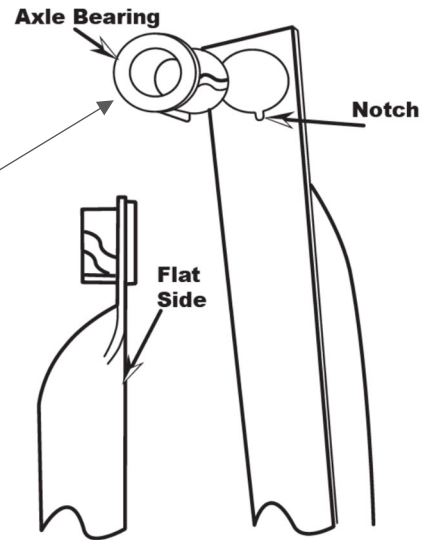
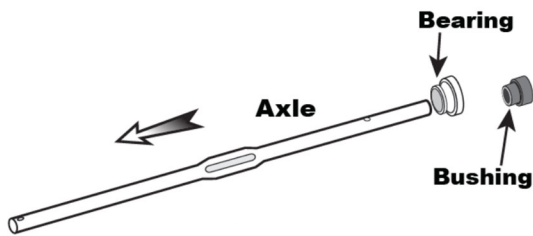

**NOW GO BACK AND TIGHTEN ALL NUTS AND BOLTS STARTING WITH FIRST STEP. DO NOT OVER TIGHTEN.**

**Step 7:** Install DRIVE WHEEL onto the AXLE and align with the cotter pin hole nearest to LOWER HANDLE as shown. Insert 2” cotter pin through wheel and through AXLE. Bend with pliers to prevent pin from falling out.

**Step 8:** Install COAST WHEEL onto the AXLE fully, then using outside cotter pin hole, insert 1” cotter pin through AXLE (not thru the wheel). Bend with pliers to prevent pin from falling out.

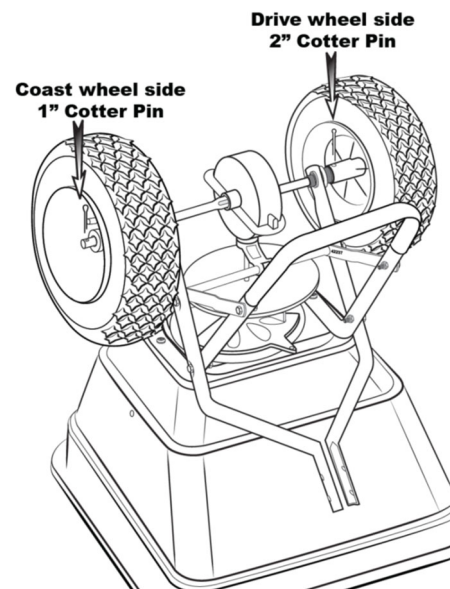

**Step 9:** New for 2021 EarthWay listened to customers who desired an adjustable handle for taller operators.

Select three ¼” x 2” bolts and three nylon lock nut to complete this step.

Notice that the square handle shaft has two sets of holes in both ends. The end that the holes are closest to the end of the handle shaft is the top. Place it as shown inbetween the handles.

Start by bolting through the handle spacer using the top most handle bar hole. Then bolt the gauge & lever assembly through the two center holes using two of your ¼” x 2” bolts.

**TIGHTEN ALL HARDWARE.**

TALL OPERATOR CONFIGURATION – with the four handle holes, use the bottom two holes for the gauge and use the top hole for the spacer.

**STANDARD POSITION**

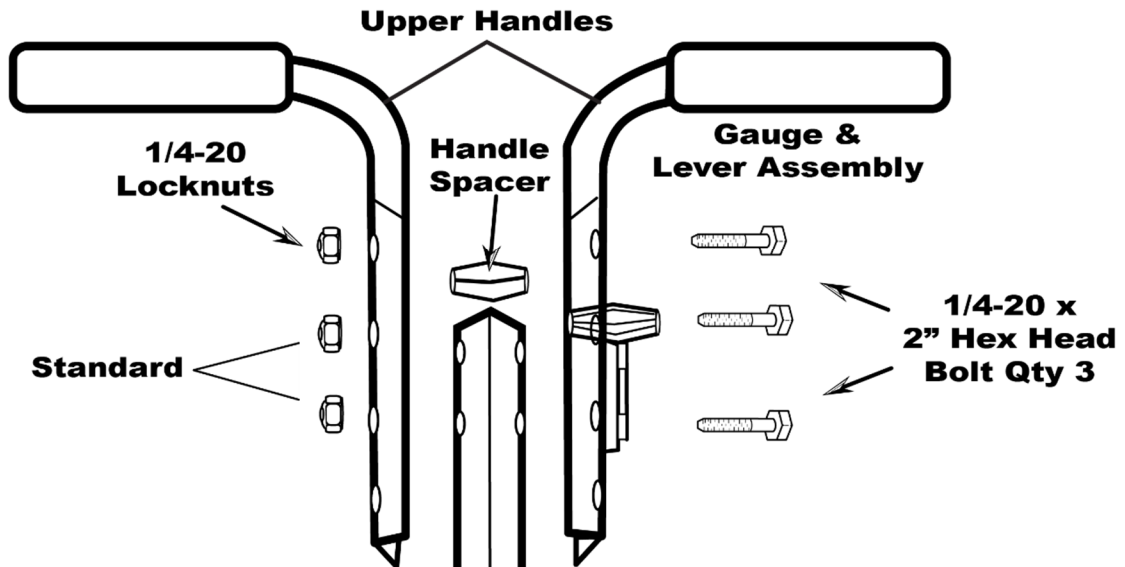

**Long Position**

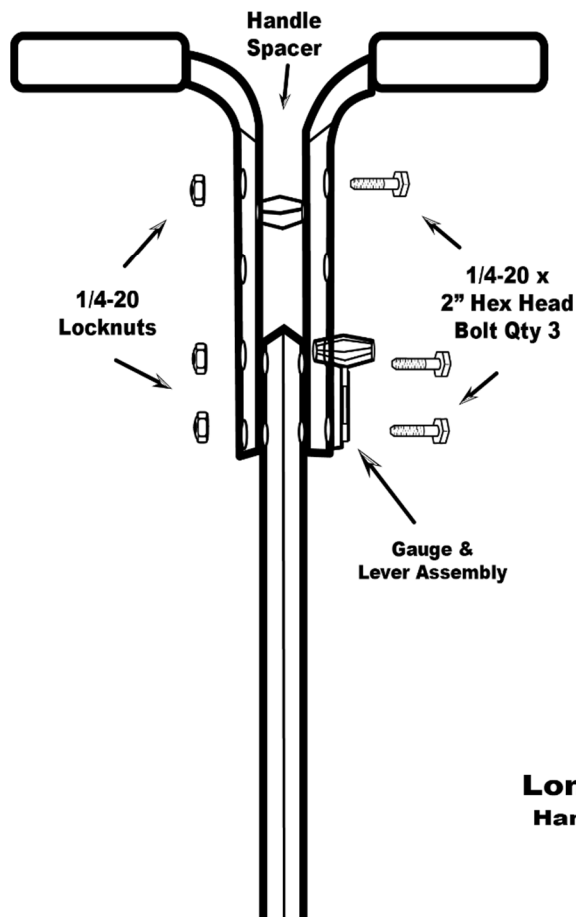

**Short Position**

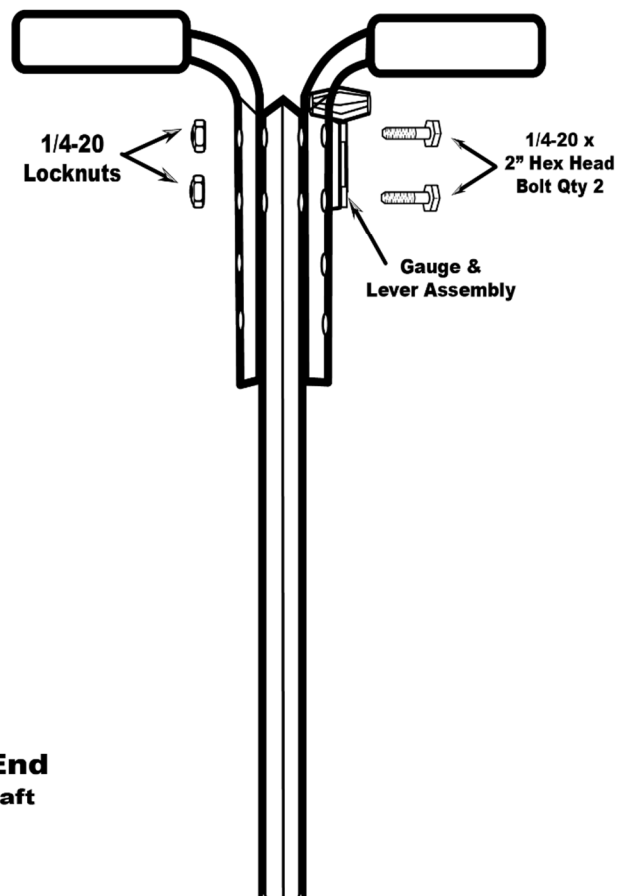

**Longer End Handle Shaft**

**Step 10:** (This step is only required if you want to change the position of the handles). **NOTE:** BEFORE INSTALLING GAUGE AND UPPER HANDLES TO HANDLE SHAFT, UPPER HANDLES FEATURE THREE POSITIONS FOR OPERATOR'S COMFORT. If operator chooses middle or upper positions, use handle spacer in hole nearest to handle grips.

Insert 2" bolt through upper handle, then through handle spacer through other upper handle and secure with locknut. **DO NOT TIGHTEN LOCKNUT YET. TIGHTEN THIS NUT LAST.**

**Step 11:**

- A. Thread hex nut onto the end of the pivot rod.
- B. Insert threaded end of the pivot rod into the shut off plate.
- C. Thread an additional hex nut on the end of the pivot rod. Use a 7/16" wrench to secure the hex nut in place around the shut off plate and pivot rod.

\* See Image below. \*

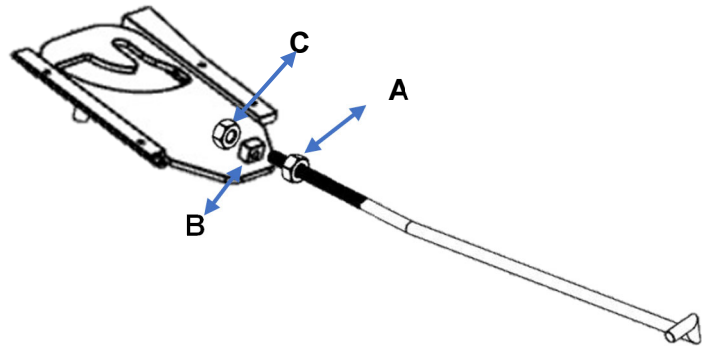

**Step 12:** Install HANDLE SHAFT to LOWER HANDLES and PIVOT & BRACKET assembly as shown. Using 2" bolts and locknuts. **TIGHTEN BOLTS AND NUTS NOW.**

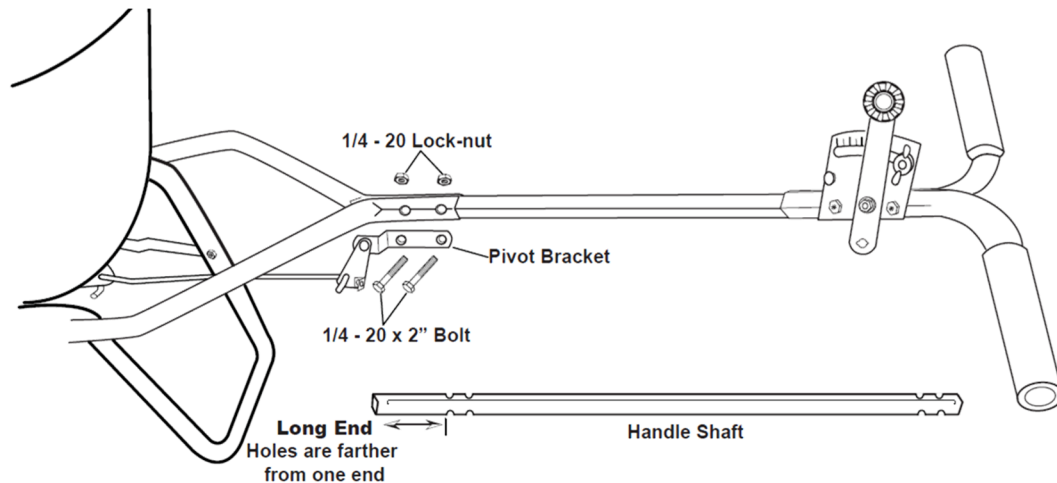

**Step 13:** Install flattened end of CONTROL ROD in to LEVER on GAUGE as shown. Turn to lock in place. Next push LEVER forward to setting "0". Align CONTROL ROD with hole in PIVOT BRACKET, pull LEVER backward to insert CONTROL ROD through hole in PIVOT BRACKET.

**Step 14:** Install (1) 1/4-20 regular nut (not a locknut) on to CONTROL ROD as shown.

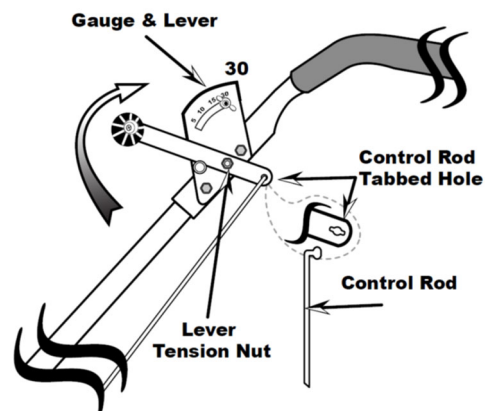
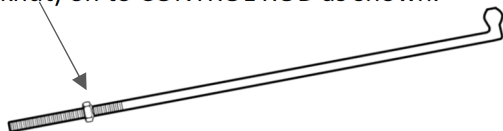

**CALIBRATION**

**Step 15:** Pull lever back to setting “30” as shown. Next push pivot & bracket forward so that the shut off plate in the hopper is in the full open position. **REMEMBER SETTING “30” ON THE FLOW CONTROL LEVER MUST PLACE THE SHUT-OFF PLATE IN THE FULL OPEN POSITION TO BE PROPERLY CALIBRATED.** Now tighten the nuts against the PIVOT BRACKET to prevent change in calibration.

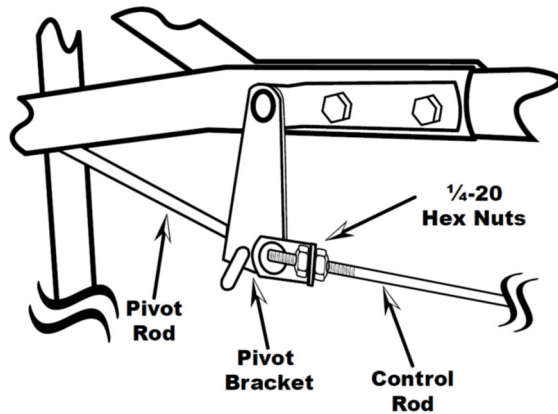

**OPERATING INSTRUCTIONS**

Before filling hopper, become familiar with the operation of this spreader.

- ☑ Move stop bolt on rate gauge assembly to the proper setting.
- ☑ While pushing spreader forward, pull control lever back to stop bolt.
- ☑ To stop, push lever forward to close flow holes before you stop moving.
- ☑ When finished, empty any remaining material from hopper.
- ☑ Thoroughly wash spreader and dry before storing. A coating of light oil will help prevent corrosion.

**CUSTOMER SERVICE**

[SUPPORT@EARTHWAY.COM](mailto:SUPPORT@EARTHWAY.COM) | [www.EARTHWAY.com](http://www.EARTHWAY.com) | 1009 Maple Street, Bristol, IN 46507

**ONE YEAR WARRANTY**

EarthWay Products, Inc. warrants this product free of defects in original workmanship and materials for a period of one year to the end user with the original purchase receipt. If a manufacturing non-conformance is found, EarthWay Products, Inc. at its discretion will repair or replace the part(s)/product at no charge provided the failure is not the result of incorrect installation, mishandling, misuse, tampering, or normal wear and tear as determined by EarthWay.

EarthWay at its discretion may require that the part(s) or product be returned along with the original purchase receipt for examination and compliance with the terms of this warranty. Do not return any product without first receiving authorization from EarthWay Products, Inc.

To seek remedy under this warranty, contact EarthWay Products, Inc. at [support@earthway.com](mailto:support@earthway.com) or write to EarthWay Products, Inc. 1009 Maple Street, Bristol, IN 46507 and describe the nature of the manufacturing defect. **SPECIFIC LIMITATIONS:** This warranty covers only the part(s) or product; any labor charges associated with repair or replacement of non-conformances are specifically excluded. Due to the corrosive nature of most fertilizers and ice melt products, EarthWay Products, Inc. makes no warranty against and specifically excludes part(s) or product degradation or failure due to corrosion or its effects.

**HOW TO ORDER SPARE PARTS – CALL or EMAIL:**

**TURF DEPOT 800-305-9255 or [earthway@turfdepot.com](mailto:earthway@turfdepot.com)**

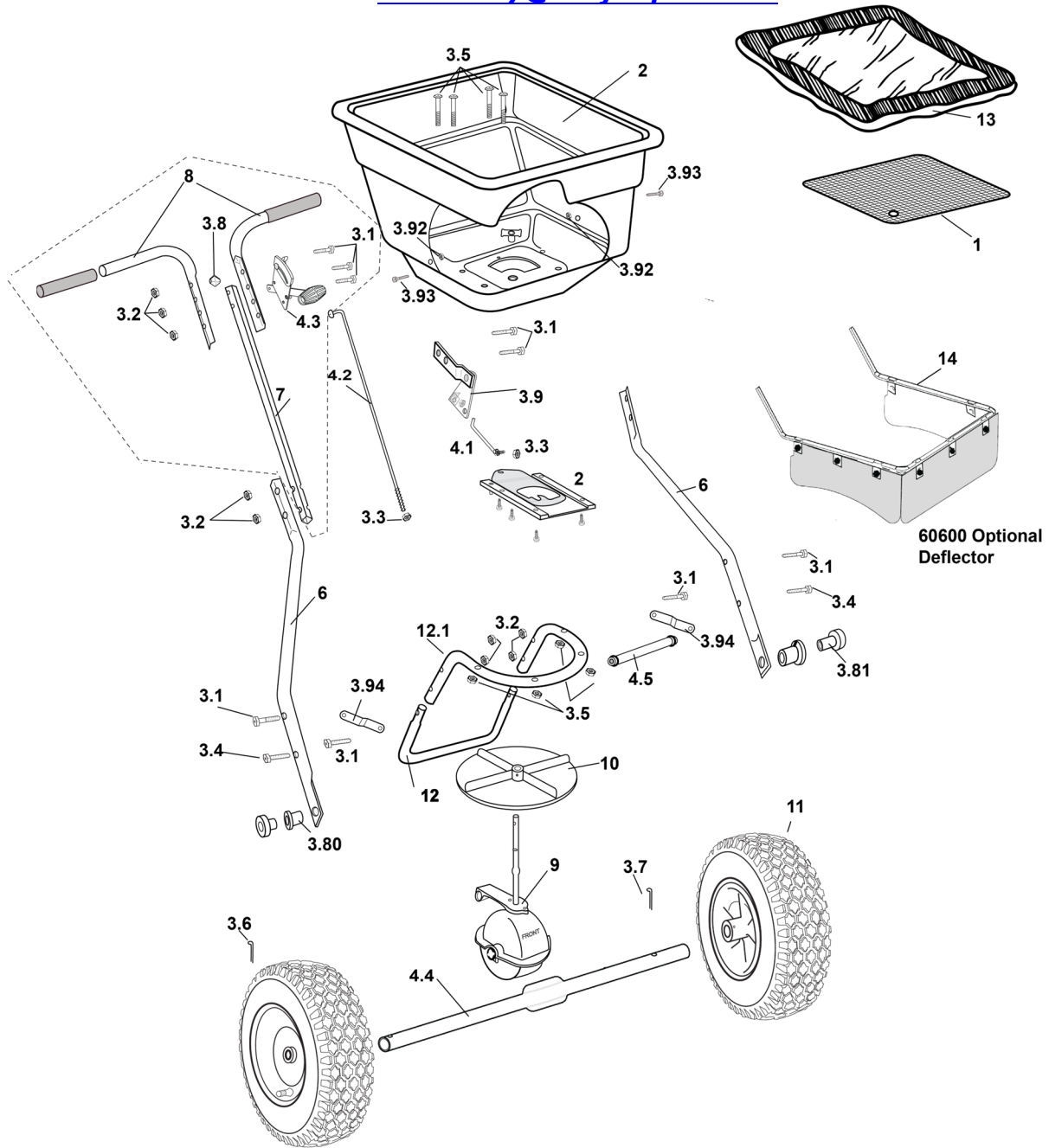

**100LB High Output Broadcast Spreader (90399) Parts List**

SERIES	PART #	DESCRIPTION	SERIES	PART #	DESCRIPTION
1	40003	SQUARE SCREEN	9	60333	GEABOX ASSEMBLY
2	99342	HOPPER & SHUTOFF ASSEMBLY	10	12110	9" ROUND DISHED IMPELLER
3	38144	HARDWARE KIT - SS (3.1 - 3.94)	11	70138	13" PNEUMATIC TIRE
4	60266	CONTROL PACKAGE (4.1- 4.5)	12	25723	FRAME FOOT
6	25222	LOWER HANDLE - SS	12.1	24111	FRAME
7	25223	HANDLE SHAFT	13	F77130	HEAVY DUTY RAIN COVER ACCESSORY
8	60175	UPPER HANDLE - SS	14	60600	THREE-SIDED DEFLECTOR ASSEMBLY